



- **Automatic De-icing System for Protection against Snow and Ice**
- **Simple to Field Install and Operate**
- **Engineered for Customer Specified Voltages**
- **Low Energy Costs**
- **User selectable Automatic, Off or Manual On Modes**
- **Available for DH Satellite Reflector Sizes: 1.8, 2.4, 3.0, 3.3, 3.7, 3.8, 3.9, 4.2, 4.5 and 5.0 Meter**

DESCRIPTION

The Viking SATCOM De-icing system consists of a factory pre-wired control unit, heater pads for reflector coverage, and a feedhorn heater. All systems are engineered to be easily assembled, installed and operated.

The control unit has three modes of operation: Automatic, Manual Off and Manual On. The Automatic mode allows the control to monitor the ambient temperature and sense the presence of moisture. An ambient temperature of less than 40 degrees F and the presence of moisture activate a heater contactor. The heater contactor is rated up to 50 amps. The heaters will remain on for a factory preset time of one hour longer than conditions warrant. The Manual Off mode turns the heaters off, regardless of the weather conditions. The Manual On mode turns the heaters on, regardless of the weather conditions. Control units are factory preset to operate on 120 to 240 volts, single or three phase power. All cabling to attach the heater pads is factory pre-wired. The larger systems have a control unit with remote moisture sensor.

The heater pads consist of heater wire sandwiched between layers of aluminum foil. Heater pads allow for a faster install without the need for templates. The aluminum foil is coated with an aggressive acrylic adhesive and a peel and stick liner. Watt density of the heater pads, depending on the reflector, is between 40 and 55 watts per square foot. The aggressive acrylic adhesive adheres to a variety of substrates and will not release when pad temperature increases. Heater pads have water resistant connectors that plug into the cables from the control unit.

The feedhorn heaters consist of heater wire attached to a strap and covered with heatshrink. They are attached to a rib on the feedhorn.

Installation of the de-ice system consists of applying the heater pads to the backside of the reflector, mounting the control unit / moisture sensor, routing power to the control unit, attaching the feedhorn heater, and connecting the heater pads to the control cables.

The De-icing systems can be custom made for a variety of antennas and applications.

Typical Installation

Instruction Manual for the DH 3.8 meter 240 Volt Full Coverage Heater System with Large Feedhorn Heater

Materials Provided List

<u>Quantity</u>	<u>Part Number</u>	<u>Description</u>
16	85434	Heater pad for 3.8 meter full coverage 240 volt
16	85435	Heater pad for 3.8 meter full coverage 240 volt
1	85433	Controller for 3.8 meter full coverage 240 V with mounting feet and feedhorn heater attached
2		Cable tie 36" for controller to mast attachment
1		Grommet for feedhorn heater cable hole
4		Foil strips for lead wire attachment
1		Instruction manual for DH 3.8 meter 60" ring 240 volt full coverage heater system with large feedhorn heater

Tools and Supplies Needed

Standard slotted screwdriver (medium)

Drill

¼" drill bit

7/16" drill bit

Adjustable wrench

Clean rags

Windex glass cleaner

Cable tie straps

Cable supplying power to the control and heater system

Read these instructions carefully and follow all of the procedures for installing this system. All electrical wiring must be performed in accordance with all applicable electrical codes.



Control and Harness

APPLY THE HEATER PADS TO THE REFLECTOR PANELS

1. Properly support the reflector so that no distortion results from heater pad attachment.
2. The surface temperature of the panel should be above 50 degrees Fahrenheit, 10 degrees Celsius for proper adhesion of the heater pads.
3. Thoroughly clean the area to be heated on the rear of the reflector with Windex and dry thoroughly.
4. Test fit the pads by laying all of them on the back of the reflector and orienting them for the best alignment. See the Heater Pad Placement and Connections drawing for the proper locations. The heater pads are designed so that the 85434 pads will fit inside of the 60 inch ring and the 85435 heater pads will fit outside of the ring.
5. Remove the backing paper from the heater pads one at a time and carefully apply to the cleaned reflector. Smooth each pad as it is placed on the reflector. The adhesive is pressure sensitive so be sure to apply pressure and rub the heater pad as it is smoothed to activate the adhesive and adhere properly.
6. Use the supplied foil strips to cover the exposed heater wire that hinges the two parts of the 85435 heater pads. Do not let the heater wire cross itself, potentially causing a hot spot.

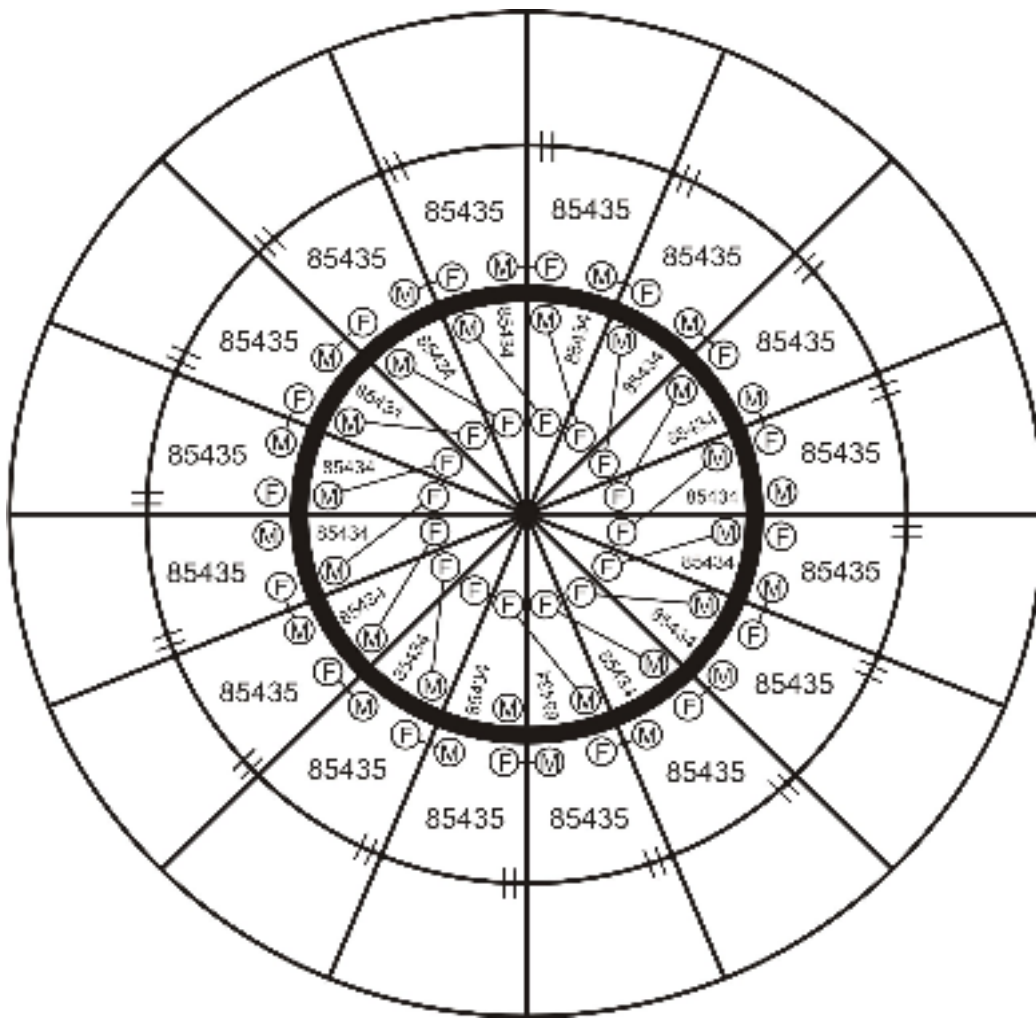

Heater Pad Placement and Connections

CONNECT THE HEATER PAD LEADS

1. Plug the heater pad connectors together as illustrated on the Heater Pad Placement and Connections drawing. The upper eight 85435 heater pads will connect together in seven places, leaving a male and female connector to plug into one of the heater pad power cables. The lower eight 85435 heater pads connect together in the same way. The sixteen 85434 heater pads connect together in fifteen places, leaving a male and female connector to plug into a heater pad power cable. The connectors are difficult to fully seat, and will not properly seal until a small snap is felt. Male leads are designated "M" and insert into female leads "F".
- 2 Eight connected 85435 pads = 21.7 – 26.6 ohms, sixteen 85434 pads = 63.4 – 77.4 ohms.
3. Use the supplied foil strips to anchor any connected leads with excess slack.

ASSEMBLE AND CALIBRATE THE REFLECTOR

ATTACH THE CONTROL ENCLOSURE TO THE MAST PIPE

1. Pass a 36" strap through the back of a hole drilled through the mounting bracket secured to the control enclosure.
2. Return the strap through the adjacent hole so that both ends of the strap are behind the control enclosure when finished.
3. Repeat step #2 for the other mounting bracket with a second strap.
4. Place the control enclosure against the mast pipe and tighten the straps sufficiently to secure. The cables exiting from the enclosure should exit in the downward direction. The final adjustment of the control enclosure must be done before the cable ties are fully tightened. The control enclosure must be mounted within six feet of the center of the reflector to ensure adequate heater pad cable length.
5. Mast pipes with a large circumference may be too large for the 36" straps. Self tapping screws may be used to secure the De-ice control to the mast pipe.

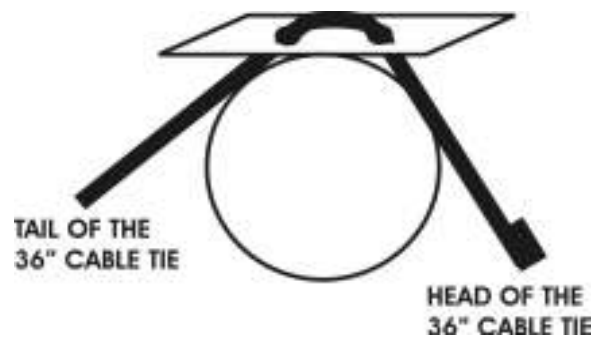

Enclosure to Mast Pipe Attachment Drawing

ROUTE HEATER PAD CABLES AND CONNECT TO THE HEATER PADS

1. Route the heater pad cables and connect to the heater pads as illustrated in the Heater Pad Power Cable drawing. All three cables are identical. Some heater pad connections will have extra leadwire length unused. Extra cable and leadwire should be hanked and secured to the ring. Do not attach cable or leadwire to anything that will not support their weight. Leave extra slack to accommodate moving parts.
2. Use tie straps (not supplied) to anchor the heater pad cables at a point where the leads enter or exit the heater pads and at a point where they branch.

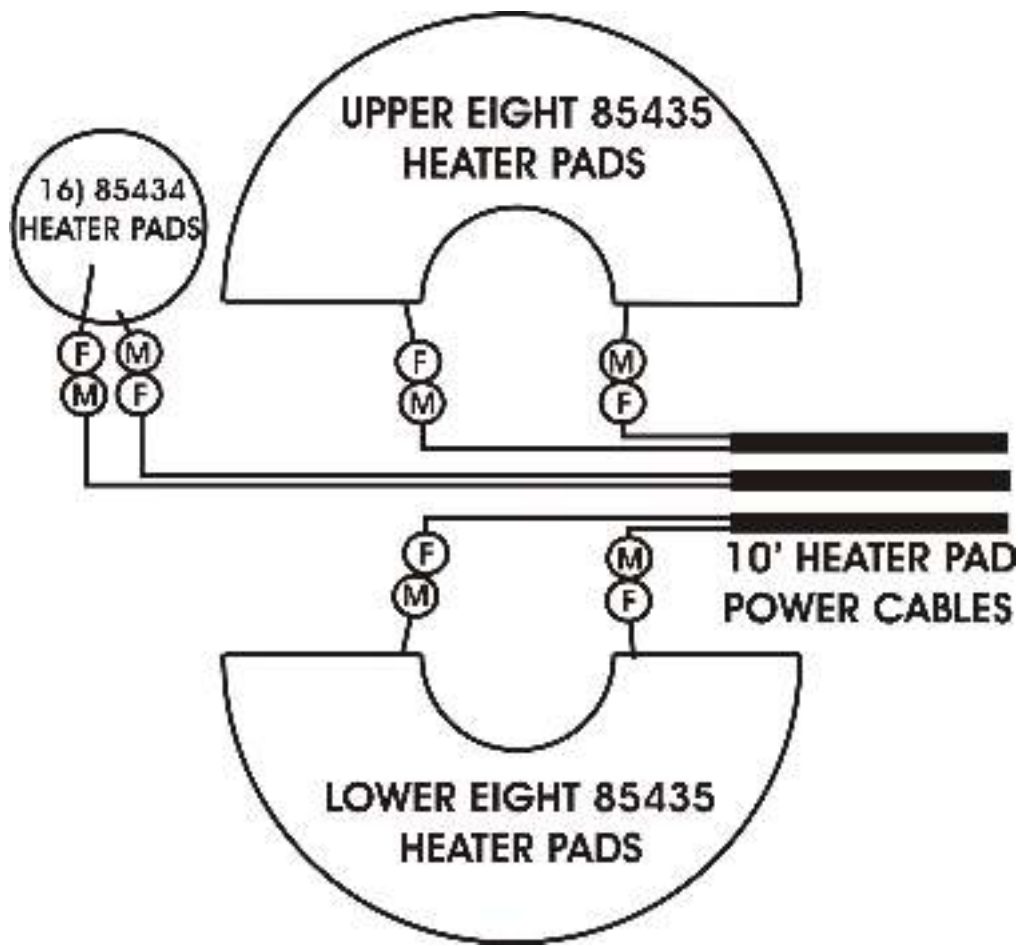

Heater Pad Power Cable Connections

MOUNT THE MOISTURE SENSOR

1. Drill a $\frac{1}{4}$ " hole in the reflector and mount the moisture sensor with the nylon insert nut provided. The sensor should be mounted in an area where the moisture sensor grid is parallel with the horizon and it will receive a representative amount of falling and blowing precipitation.
2. Use one tie strap (not supplied) to anchor the sensor cable near the moisture sensor.

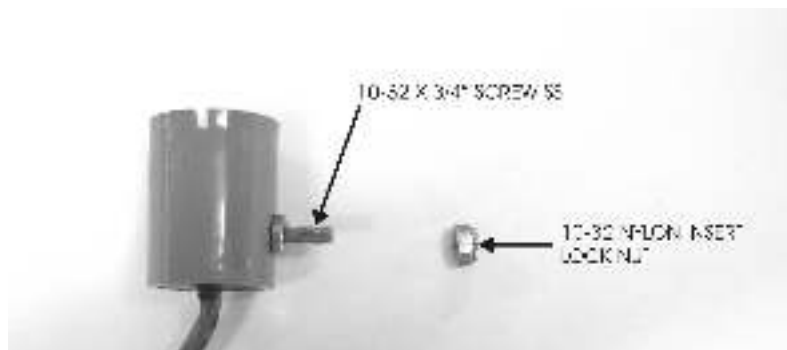

ATTACH THE FEEDHORN HEATER TO THE FEEDHORN

1. Route the feedhorn heater cable along the feedhorn support arm.

** For inboard feedhorn support arms, drill a 7/16" hole through the reflector near a support arm mount and insert a grommet into the hole. Unplug the heater from the cable by pulling the connectors apart. Do not pull on the wires. The feedhorn heater cable should now pass through the hole and follow the support arm. Plug the heater and the cable back together.

2. Place the feedhorn heater around the feedhorn and loosely attach it by passing the tail of the strap through the head. Be sure the heater wire in the feedhorn heater is against the feedhorn.

3. Position the heater with the head of the cable tie and the connectors toward the bottom of the feedhorn and tighten the strap fully. Do not cut the tail off of the feedhorn heater at this time. It will be done when the final test of the system is performed and the feedhorn heater is warmed. See the Feedhorn Heater Placement picture for proper placement.

4. Use one tie strap (not supplied) to anchor the Feedhorn Heater Cable near the feedhorn heater branch.



Feedhorn Heater Placement

ROUTE POWER TO THE CONTROL ENCLOSURE

1. Unscrew the cordgrip nuts sufficiently to allow the cables to move in and out of the enclosure. Sufficient cable slack should still be available to move the cables in and out.

2. Remove the four screws securing the cover on the control enclosure.

3. Remove the enclosure lid as the cables are fed through the cordgrip.

4. Wire 240 volt single phase AC power to the L1 and L3 positions on the contactor. An empty hole has been supplied in the side of the enclosure for wiring power in.

* The entire system supplies 5625 watts of heat and draws approximately 23.4 amps.

5. Replace the enclosure cover as cable is pulled from the inside of the enclosure. Leave a minimum of one inch of the SJTW cable protruding from the inside of the cordgrips.

6. Tighten the cordgrips until all cables are secured. Over tightening can damage the cordgrip.

7. Replace the four cover screws securing the lid and tighten sufficiently.

SECURE ALL CABLES WITH TIE STRAPS

1. Secure the entire lengths of the heater pad cables, the feedhorn heater cable, and the moisture sensor cable with tie straps (not supplied).

TEST THE HEATER SYSTEM

1. Apply 240 VAC single phase power to the system.

2. Allow the sensor to go through its start-up test.

3. When the sensor enters the Automatic Enabled mode (steady green indicator), push the selector switch twice to place the sensor in the Manual On mode (steady amber indicator).

4. Wait a few minutes and feel the surface of the reflector for warmth. The feedhorn heater should also feel warm to the touch. Retighten the feedhorn heater strap while the heater is warm and cut off all but ½” of the excess strap material.

5. Return the system to the Automatic Enabled mode by pressing the selector switch one more time.

FINALIZE ALL OTHER INSTALLATION ISSUES

DE-ICE CONTROL SPECIFICATIONS

The control operates electric heaters to prevent the build-up of snow and ice on the reflector when conditions are conducive to their formation. That is, during precipitation when the ambient temperature is below 40 F.

1. The controller will assure a minimum On time of approximately one hour. The system will continue to supply heat as long as conditions warrant it.

2. The controller provides AUTO, OFF, and ON functions. These modes are user selectable through a single push button switch which alternates through each mode.

- The normal power-up mode is AUTO. In this mode, the controller will turn on the heater contactor when conditions are conducive to the formation of snow and ice.

- When in the OFF mode, the heater contactor remains disengaged regardless of the weather conditions.

- When in the ON mode, the heater contactor is engaged until the controller mode is changed or the power is reset.

3. The control provides two indicator lights. The green indicator lights when the control is in the AUTO mode. The yellow indicator lights when the heater contacts are closed and the heaters are on.
4. The moisture sensor is heated to melt snow and ice for detection as moisture.
5. The controller has been factory preset to operate on 240 volt single phase power.
6. The heater contactor provided is rated at 50 amps resistive. The heater system draws approximately 23.4 amps.
7. The control panel and heater contactor are housed in a UL and CSA rated, weather resistant, gasketed enclosure.

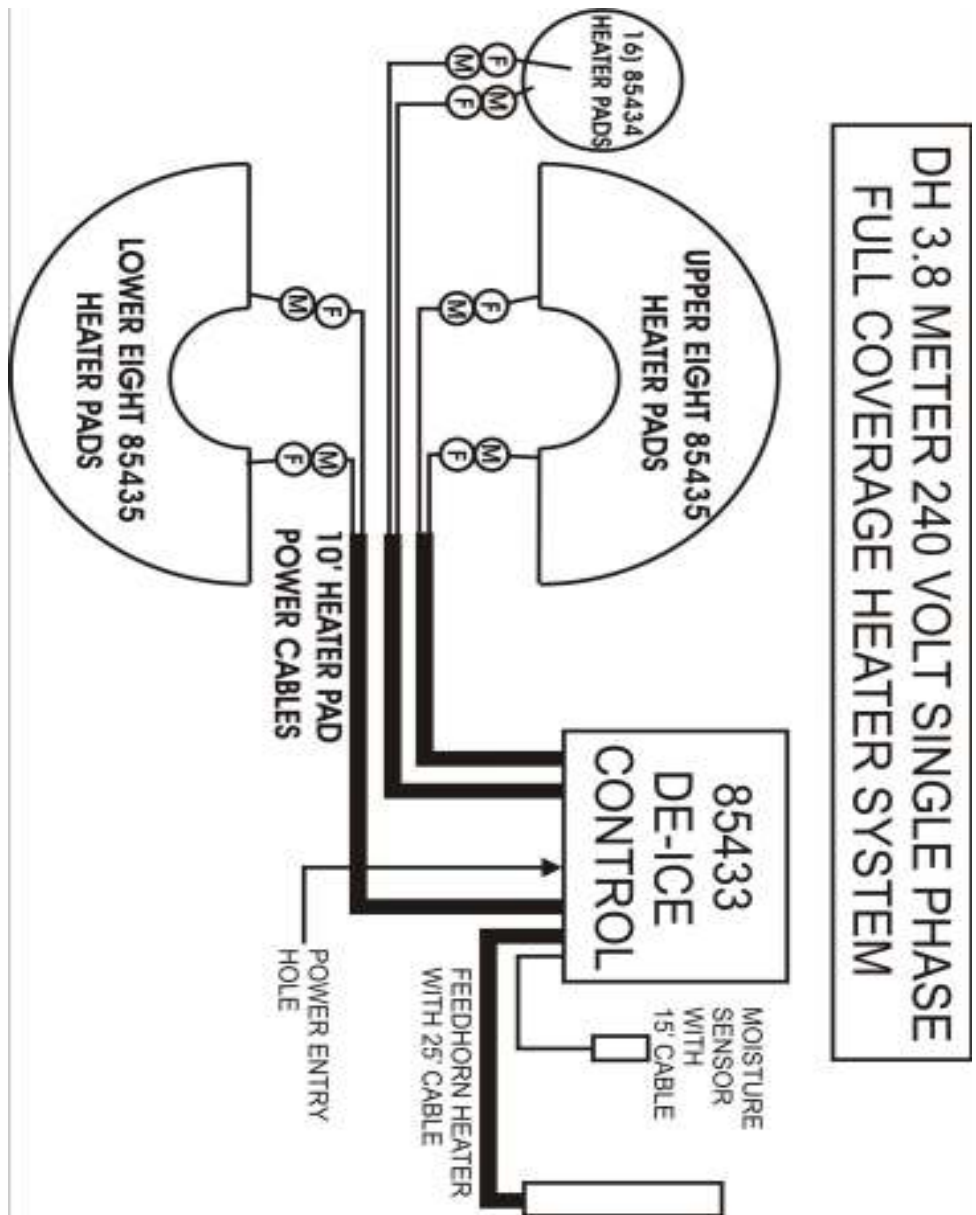

System Wiring